

Pump Pompa	Pressure Pressione		Volume Portata				RPM giri/min		Power Potenza			
			l/min		GPM				HP		kW	
	bar	PSI	50 Hz	60 Hz	50 Hz	60 Hz	50 Hz	60 Hz	50 Hz	60 Hz	50 Hz	60 Hz
MXT1015	150	2175	100	120	25,9	31,1	1450	1740	37,7	45,2	27,7	33,2
MXT8515	150	2175	85	102	22,2	26,6	1450	1740	32,3	38,8	23,8	28,6
MXT7020	200	2900	70	84	18,5	22,2	1450	1740	35,9	43	26,4	31,7

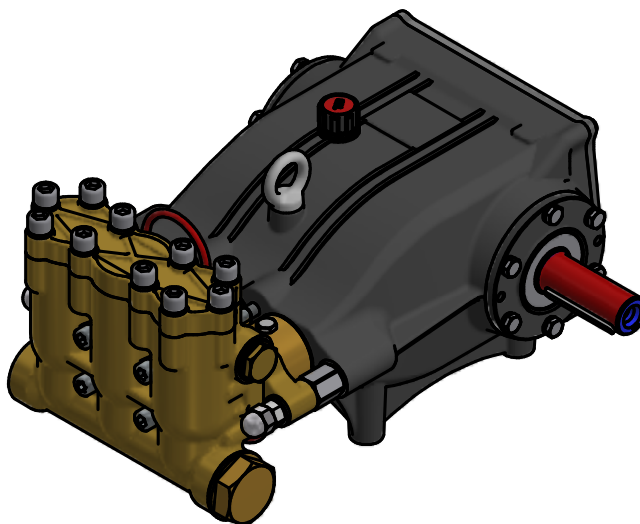

Dimensioni d'ingombro

Overall dimensions

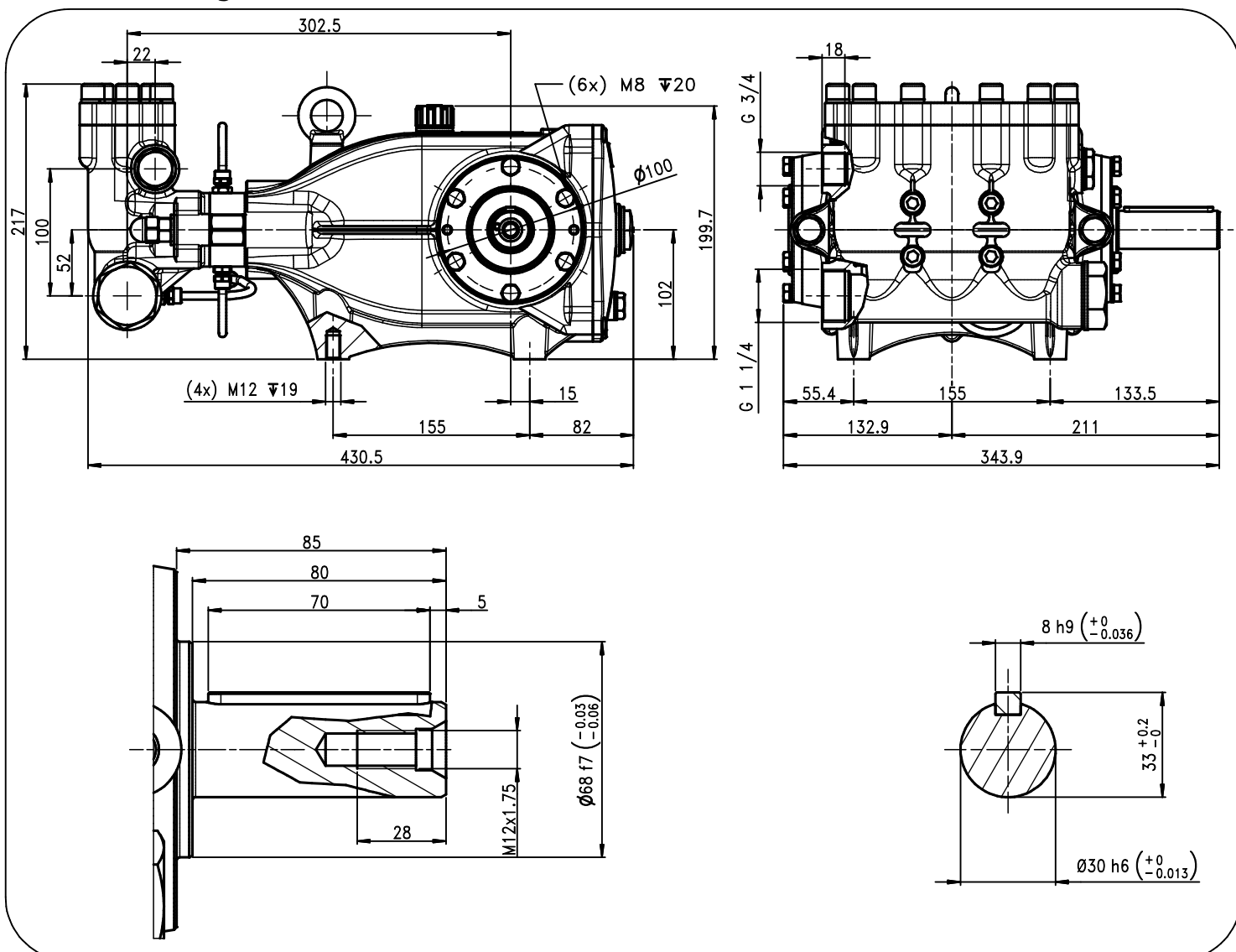

Lubrificazione: Olio SAE 10W-40
 Capacità: 2,3 Litri
 Peso pompa: 28,5 Kg

Rev. 8 09-21

Lubrication: SAE 10W-40 Oil
 Capacity: 2,3 Litres
 Weight: 28,5 Kg

(*) disponibili solo in kit
 available only in kit

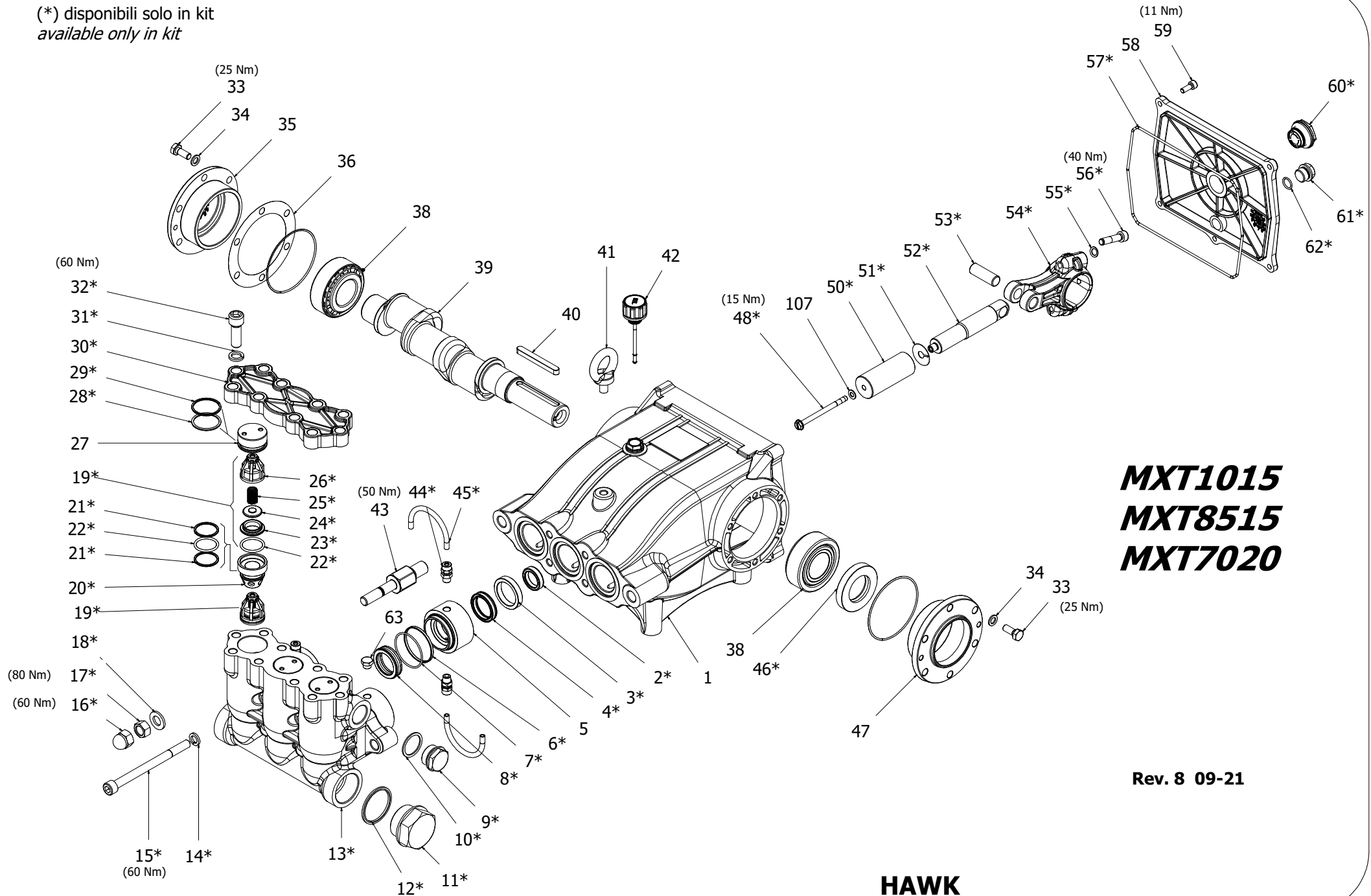

MXT1015
MXT8515
MXT7020

Rev. 8 09-21

HAWK
Pompe MXT serie 2015
MXT pumps 2015 series

MXT SERIES 2015

ORDINARY MAINTENANCE KIT / KIT MANUTENZIONE ORDINARIA

KIT	Item Pos	Part Number Codice	Description	Descrizione	Q.TY per pump - Q.TA per pompa	MXT1015	MXT8515	MXT7020
A	4- 6- 7- 8	1.099-801.0	PISTON SEAL PACKING	GUARNIZIONI PISTONE	1			
B	19 (22-23-24-25 26) 21 22- 28- 29	1.099-802.0	VALVE	VALVOLE	1	•	•	•

EXTRAORDINARY MAINTENANCE KIT / KIT MANUTENZIONE STRAORDINARIA

KIT	Item Pos	Part Number Codice	Description	Descrizione	Q.TY per pump - Q.TA per pompa	MXT1015	MXT8515	MXT7020
C	19 (22-23-24-25 26) 20 21-22-28 29	1.099-804.0	COMPLETE VALVE	VALVOLE COMPLETE	1			
D	2	1.099-766.0	PLUNGER OIL SEALS	TENUTE OLIO ASTA PISTONE	1			
E	48- 49- 50- 51	1.099-803.0	PLUNGER	PISTONE	3			
F	37- 46- 57- 60- 61- 62	1.099-805.0	KIT CRANCKASE SEALS	KIT TENUTE CARTER	1			
G	14- 15- 16- 17- 18	1.904-451.0	MANIFOLD SCREWS	VITI TESTATA	1	•	•	•
H	52- 53- 54- 55- 56	1.904-428.0	PLUNGER ROD-CONNECTING ROD	ASTA PISTONE-BIELLA	3			
I	44- 45	1.904-456.0	COMPLETE CIRCULATION PIPES	TUBI RICIRCOLO	1			
L	3- 4- 5- 6- 7- 8	1.904-968.0	COMPLETE SEAL PACKING	KIT COMPLETO GUARNIZIONI	1			
M	9- 10- 11- 12- 13- 27 30- 31- 32	1.904-969.0	CYLINDER HEAD KIT	KIT TESTATA	1			

“Q.TY by Pump” => Necessary quantity to repair one pump
 “Q.TA’ per Pompa” => Quantità necessaria per riparare una pompa

Part number Codice	Description	Descrizione
1.099-669.0	TOOL KIT	TOOL KIT
1.904-418.0	TOOL KIT EXTRAORDINARY	TOOL KIT STRAORDINARIA

IMPORTANT IMPORTANTE

* Part available ONLY in kit
 Disponibile SOLO in kit

(...) Parts pre-assembled
 Parti pre-assemblate

PARTS LIST LISTA PARTI

Item Pos	Part Number Codice	Description	Descrizione	KIT	Q.TY Q.TA	MXT1015	MXT8515	MXT7020
1	9.850-373.0	CARTER	CARTER		1			
2*		PLUNGER OIL SEAL	ANELLO RADIALE	D	3			
3*		SUPPORT RING	PRESSORE	L	3			
4*		"U" SEAL	GUARN. "U"	A - L	3			
5*		INTERMED. RING	DIFFUSORE	L	3			
6*		BACK RING	ANELLO ANTIESTR.	A - L	3			
7*		O-RING	O-RING	A - L	3			
8*		"U" SEAL	GUARN. "U"	A - L	3			
9*		BRASS PLUG G3/4"	TAPPO G3/4	M	1			
10*		COPPER SPACER G3/4"	GUARNIZIONE G3/4"	M	1			
11*		BRASS PLUG G1" 1/4	TAPPO G1" 1/4	M	1			
12*		BONDED SEAL G 1" 1/4 NBR	BONDED SEAL G 1" 1/4 NBR	M	1			
13*		MANIFOLD HOUSING	TESTATA OTTONE Ø30	M	1			
14*		SPRING WASHER	ROSETTA ELAST.	G	4			
15*		MANIFOLD HOUSING SCREW	VTCEI M10 x 130 ISO 4762-p	G	4			
16*		NUT CAP	DADO	G	2			
17*		NUT	DADO M12 UNI5588	G	2			
18*		WASHER	ROSETTA	G	2			
19*		VALVE ASSEMBLY	VALVOLA PREMONTATA	B - C	6			
20*		VALVE CAGE	GABBIA VAM IMPILATA	C	3			
21*		BACK RING	ANELLO ANTIESTR.	B - C	6			
22*		O-RING	O-RING	B - C	9			
23*		VALVE SEAT	SEDE VAM	B - C	6			
24*		VALVE PLATE	PIATTELLO VAM	B - C	6			
25*		VALVE SPRING	MOLLA VAM	B - C	6			
26*		VALVE CAGE	GABBIA VAM	B - C	6			
27*		VALVE SPACER CAP	DISTANZIALE TAPPO VAM	M	3			
28*		O-RING	O-RING	B - C	3			
29*		BACK RING	ANELLO ANTIESTR.	B - C	3			
30*		MANIFOLD HOUSING COVER	COPERCHIO TESTATA	M	1			
31*		WASHER	ROSETTA	M	10			
32*		COVER SCREW	VITE COPERCHIO TESTATA	M	10			
33	9.851-503.0	BEARING HOUSING SCREW	VITE FLANGIA CUSCINETTI		12			
34	9.851-114.0	WASHER	ROSETTA M8 UNI 6592V		12			
35	9.850-641.0	BEARING HOUSING	FLANGIA CHIUSA		1			
36	9.850-556.0	SHIM 0,1mm	DISTANZIALE FLANGIA 0,1mm		1			
	9.850-557.0	SHIM 0,05mm	DISTANZIALE FLANGIA 0,05mm		1			
37*		O-RING	O-RING	F	2			

Item Pos	Part Number Codice	Description	Descrizione		Q.TY Q.TA	MX1015	MX18515	MX17020
38	9.851-963.0	ROLLER BEARING	CUSCINETTO		2	•	•	•
39	9.850-229.0	CRANKSHAFT SPTO Ø30	ALBERO SPTO Ø30		1	•		
	9.850-231.0	CRANKSHAFT SPTO Ø30	ALBERO SPTO Ø30		1		•	
	9.850-232.0	CRANKSHAFT SPTO Ø30	ALBERO SPTO Ø30		1			•
40	9.850-450.0	CRANKSHAFT KEY	LINGUETTA		1			
41	9.851-457.0	EYEBOLT	GOLFARE		1			
42	9.851-287.0	OIL DIP STICK	TAPPO SFIATO OLIO		1			
43	9.850-555.0	MANIFOLD HOUSING SPACER	TIRANTE TESTATA		2			
44*		FITTING	RACCORDO	I	6			
45*		RED PIPE	TUBO ROSSO	I	4			
46*		PLUNGER OIL SEAL	ANELLO RADIALE	F	1			
47	9.850-642.0	BEARING HOUSING	FLANGIA APERTA		1			
48*		PLUNGER INOX SCREW	VITE INOX PISTONE	E	3			
49*		PLUNGER COPPER SPACER	ROSETTA RAME	E	3			
50*		PLUNGER	PISTONE	E	3			
51*		COPPER SPACER	ROSETTA PISTONE	E	3			
52*		PLUNGER ROD	ASTA GUIDA PISTONE	H	3	•	•	•
53*		CONNECTING ROD PIN	SPINOTTO	H	3			
54*		CONNECTING ROD	BIELLA	H	3			
55*		SCHNORR WASHER	ROSETTA SCHNORR	H	6			
56*		CONNECTING ROD SCREW	VITE BIELLA	H	6			
57*		O-RING	O-RING	F	1			
58	9.850-393.0	CRANKCASE COVER	COPERCHIO POSTERIORE		1			
59	9.851-474.0	COVER SCREW	VITE COPERCHIO		5			
60*		SIGHT GLASS G 3/4"	SPIA LIVELLO OLIO G3/4	F	1			
61*		BRASS PLUG G3/8"	TAPPO G3/8"	F	1			
62*		O-RING	O-RING	F	1			
63	9.851-353.0	CUP	TAPPO		1			